

PCB LAYOUT

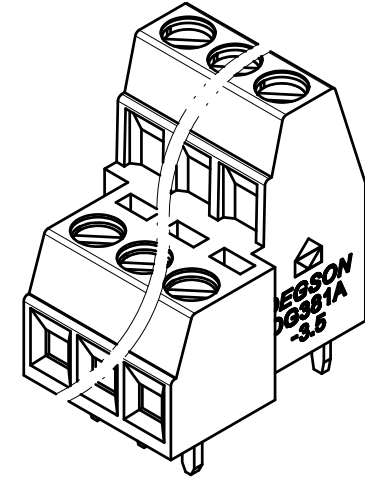
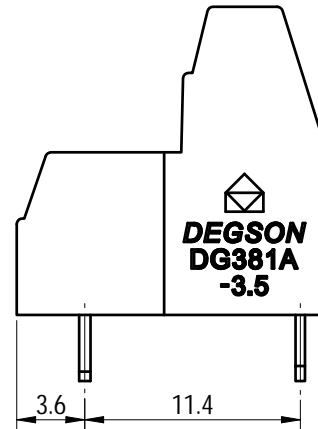
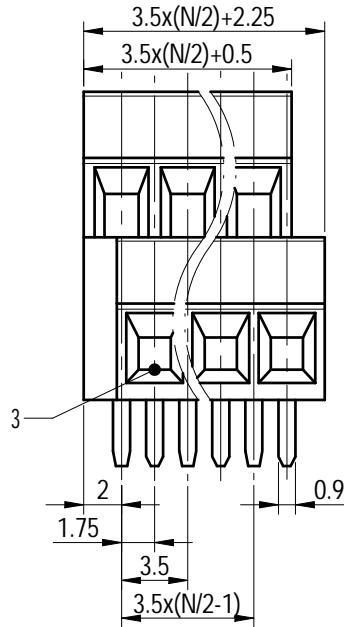
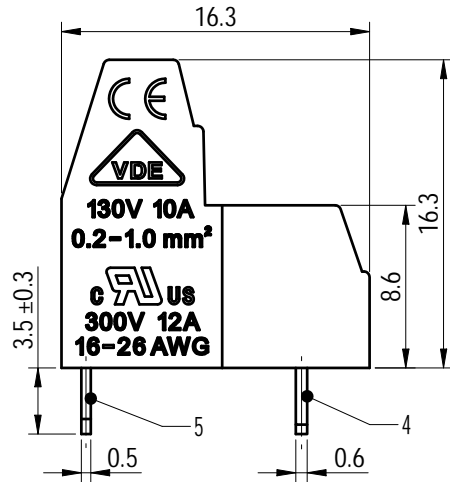
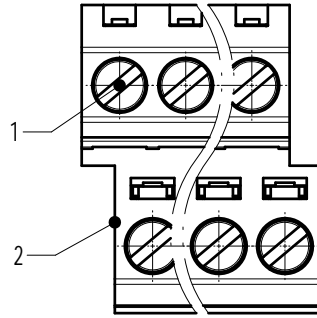
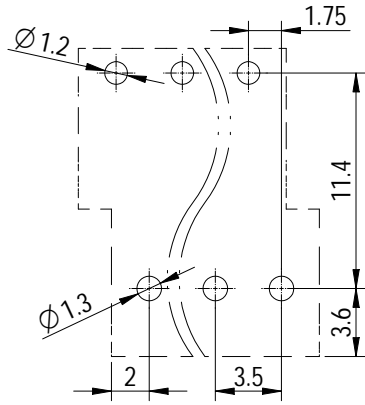

未注公差/General tolerances (mm)													0.1/10
0	>3	>6	>10	>18	>30	>50	>80	>120	>180	>250	>315	>400	
~3	~6	~10	~18	~30	~50	~80	~120	~180	~250	~315	~400	~500	>500
±0.12	±0.18	±0.22	±0.26	±0.31	±0.37	±0.57	±0.80	±0.93	±1.05	±1.15	±1.60	±2.20	±2.50

UL 标准/UL Standard:	B	C	D
额定电压/电流/Rated Voltage(V)/Current(A)	300/12	/	/
IEC 标准/IEC Standard:			
过压类别/Overvoltage Category/污染等级/Pollution Degree	III/3	III/2	II/2
额定电压/电流/Rated Voltage(V)/Current(A)	/	130/10	/
工频耐压/Withstanding Voltage (V/1Min)	AC1250		
螺丝扭矩/Torque Tightening(N·m/Lb.in)	M2, 0.2/1.77		
线径范围(硬线和软线)/Wire Range(rigid and flexible)(AWG/mm²)	26~16/ 0.2~1.0		
间距/Pitch(mm)/线数范围/Poles	3.5/N=04~32P		
剥线长度/Stripping length(mm)	5~6		
使用温度范围/Operating temperature(°C)	-40~+105		
符合RoHS环保要求/Conform to RoHS	Yes		

Note:  
The A&Z (H) in the name means: A(H) and Z(H).

ITEM	NAME OF PART	MATERIAL	NOTES
5	Pin Header2	Copper Alloy	Sn Plated
4	Pin Header1	Copper Alloy	Sn Plated
3	Cage	Copper Alloy	M2/Ni Plated
2	Housing	PA66	UL94V-0
1	Screw	Steel	M2/Zn Plated

		MATERIAL: /	SURFACE/COLOR: /	
APPD: 兰春华 2023.03.03		MAT NO./REV: - / 00		MAT STATUS: 批量
CHKD: 陈招 2023.03.02		NAME		
DRFT: 柳学龙 2023.03.02		DG381A-3.5-XXP-1Y-80A&Z(H)		
DRAWING NO.	TYPE	DRAWING STATUS	SCALE	SHEET
200025710	CUSTOMER DRAWING	已发布	2.5:1	1/1

REV	ECN	DESCRIPTION	DRFT	DATE
00			柳学龙	2023.03.02

Transfer or duplication of this document as well as the utilization or communication of its contents are prohibited unless authorized in writing by the copyright holder. All rights reserved for patent. 除专利注明情况外，其他部分均按实际情况处理。未经许可，不得复制或传播。 除专利注明情况外，其他部分均按实际情况处理。 除专利注明情况外，其他部分均按实际情况处理。